



1003 48TH STREET
NEWPORT NEWS, VA 23607
PHONE: (757) 327-0036
FAX: (757) 327-0552
info@chasefiltercompany.com



FILTERS FOR USE IN OXYGEN SYSTEMS

FAULT TOLERANT • IGNITION RESISTANT • HIGH PRESSURE

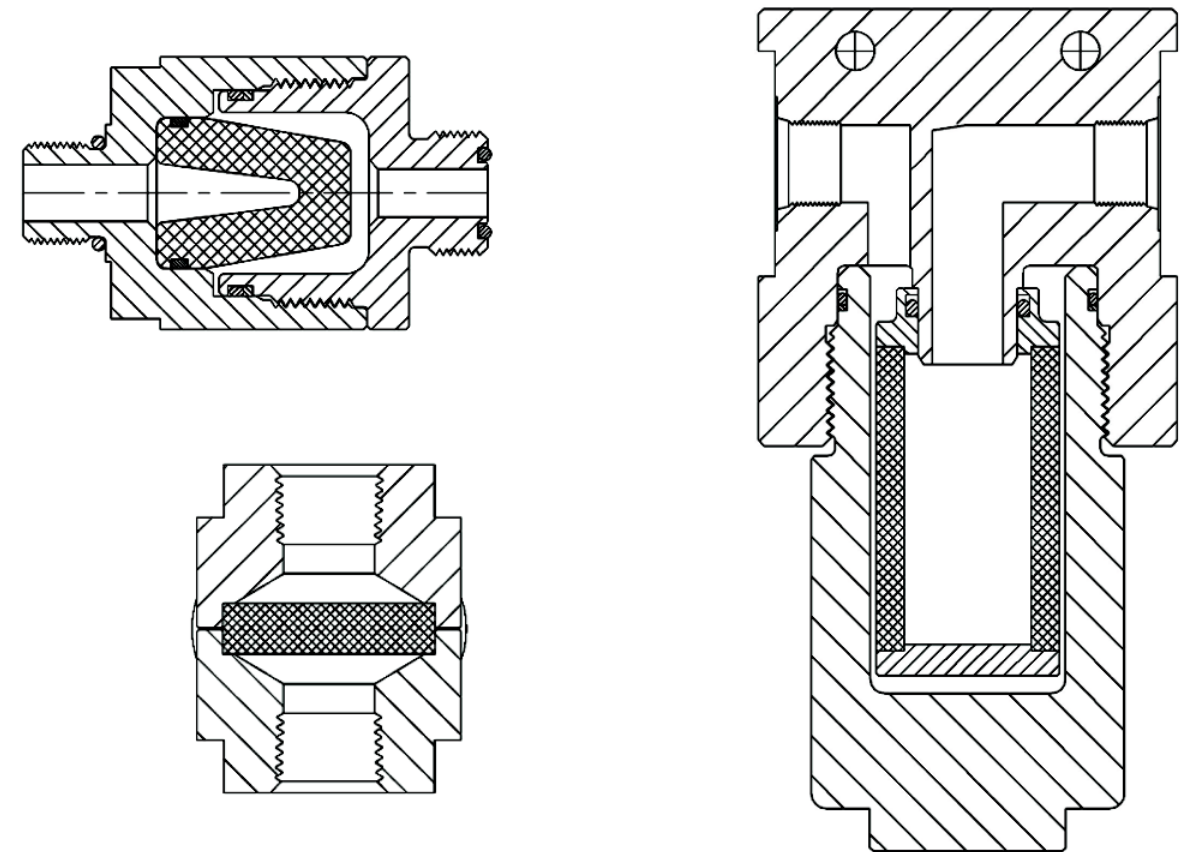

Chase Filters and Components, LLC

1003 48th St.
Newport News, VA 23607

Phone: 757-327-0036
Fax: 757-327-0552
E-mail: info@chasefiltercompany.com

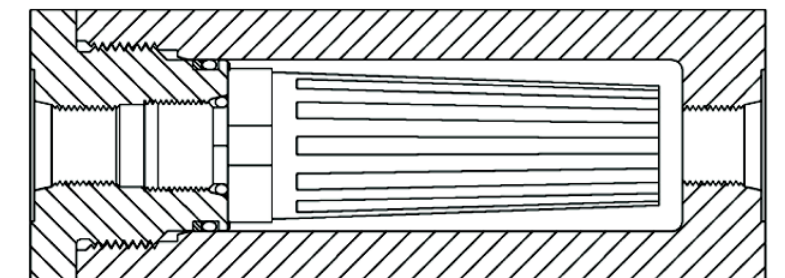

IGNITION RESISTANT, FAULT-TOLERANT OXYGEN FILTERS

ASTM G-175 defines fault tolerance as:

- (1) A decreased probability of ignition as evaluated by rapid pressurization testing, and
- (2) A decreased consequence of ignition as evaluated by forced ignition testing.

The ASTM G-175 standard specifically applies to oxygen service pressure regulating valves for medical and emergency breathing system applications. From its definition of Fault Tolerance above, the ASTM testing is broken down into two processes. The first process deals with the probability of ignition, and the second focuses on the severity of consequences should an ignition occur. Chase Filters and Components (CFC), working in conjunction with Wendell Hull and Associates, has adopted the testing criteria from ASTM G-175, and applied it to the CFC Oxygen Filter lines. There is no standard in existence that specifically pertains to oxygen filters.

Filters, like pressure regulating valves, restrict or obstruct flow. When rapidly subjected to a flow of high pressure oxygen, near adiabatic compression can occur, with temperatures rising sufficiently to support ignition. CFC has applied this same rationale from the obstructive nature of a regulating valve to deem ASTM G-175 testing appropriate for filters.

For a filter to be labeled Ignition Resistant and Fault Tolerant, it must first successfully pass an Oxygen Pressure Shock Test performed according to ISO 10524. The filter must then successfully pass the Promoted Ignition Testing, which incorporates a catalyzing 'pill' at a minimum oxygen pressure



CFC 50 Series Brass Tee Filter after modified ASTM G-175 testing at 5000 psig oxygen.

of 2,200 psi, without: internal parts ejected, molten or burning material ejected or breach of the body. In addition, verification that 90 % of the pill has been consumed, must take place.

The CFC Oxygen Filter lines are manufactured from brass and incorporate a minimally restrictive sintered brass element design. Brass has superior resistance to ignition over other materials such as stainless steel and aluminum. "Based on data from promoted combustion testing, aluminum supports burning at ~25 psi, stainless steel ~500 psi, on the other hand, brass and bronze will not support burning at pressures up to 10,000 psi" (ASTM G-175).

CFC oxygen filters are designed to contain the consequences of an ignition event, therefore protecting the downstream piping and system components. Since the inherent purpose of a filter is to trap particles, CFC and Wendell Hull decided the ASTM G-175 test needed to be modified to include a controlled amount of contamination to the filter element before the ignition event. In addition to the increased energy provided by the contamination, an aluminum witness plate was added to the piping downstream of the filter. In order for a filter to earn the CFC Ignition Resistant, Fault Tolerant designation, and be placed into production, there can be no evidence of damage to the witness plate following the ASTM G-175 testing. CFC filters have passed the oxygen testing up to 5,000 psi. It should be noted the stainless steel filters that were tested, failed the Promoted Ignition Testing at 3,000 psi oxygen.



316 SST Tee Filter after modified ASTM G-175 testing at 3000 psig oxygen.

How to Order Oxygen Series Filters

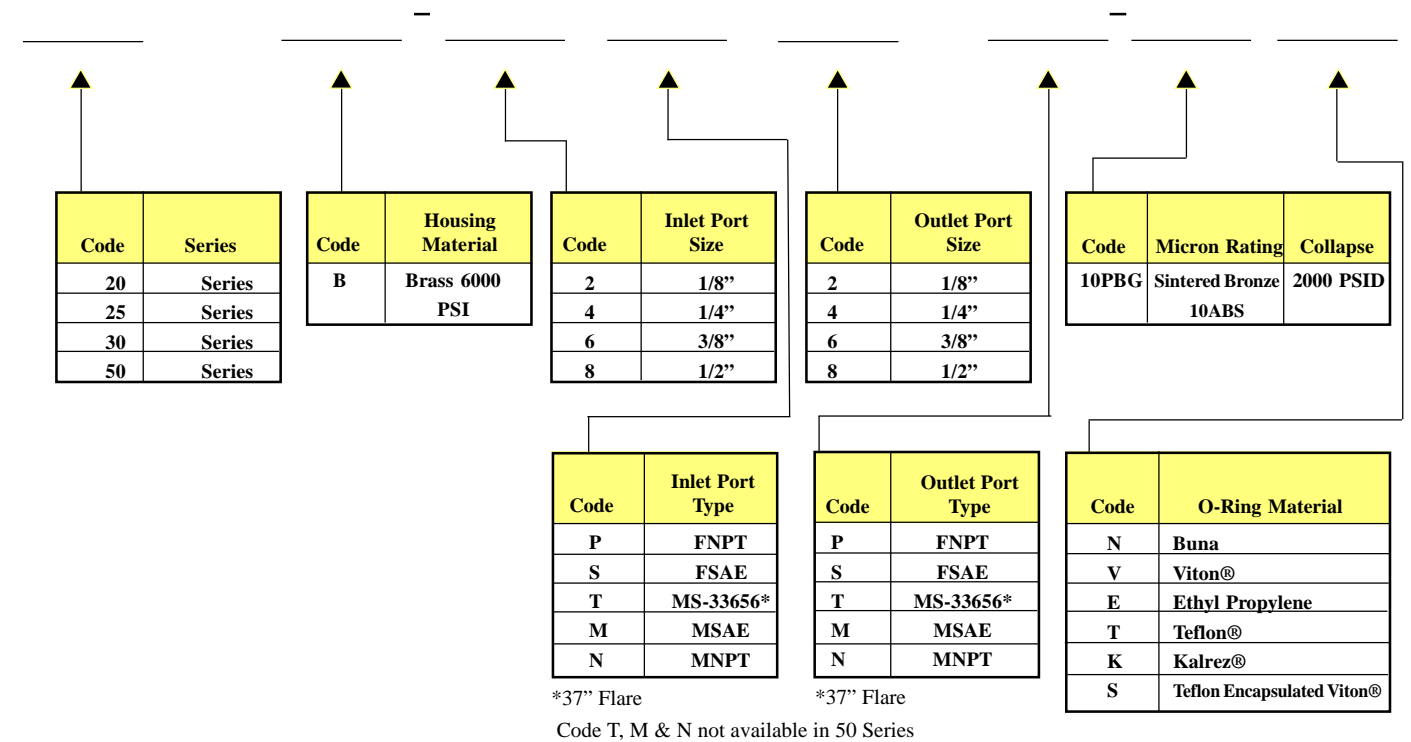

20 Series



25 Series



30 Series



50 Series



Chase Filters and Components • 1003 48th Street • Newport News VA 23607



50 SERIES BRASS TEE FILTER

RATED OPERATING PRESSURE:
6000 PSIG

FLOW CAPABILITY:
CV-3.0

SAFE, RELIABLE,
SIDE-SEAL DESIGN



MANY PORTING OPTIONS
AVAILABLE

10 MICRON SINTERED
BRONZE REPLACEABLE
ELEMENT

DESIGN HAS SUCCESSFULLY PASSED MODIFIED ASTM G175 PHASE 2 PROMOTED
IGNITION TEST WITH 5000 PSIG OXYGEN

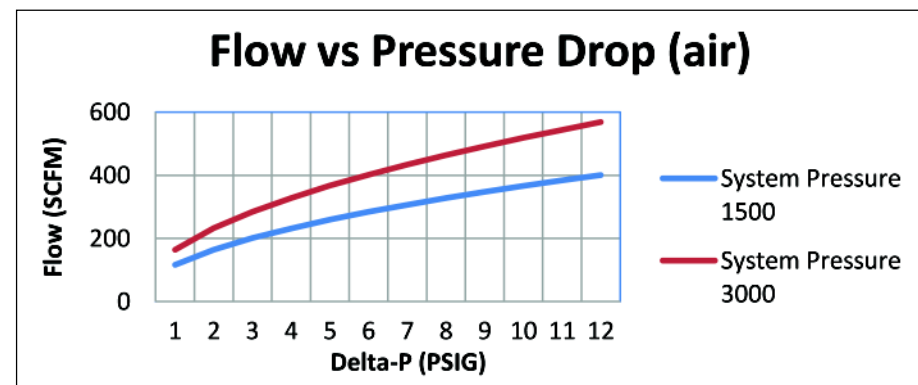

Chase Filters and Components • 1003 48th Street • Newport News VA 23607



20 SERIES BRASS INLINE FILTER

OPERATING PRESSURE TO
6000 PSIG

FLOW CAPABILITY:
CV RANGE .1 - .3

MANY PORTING OPTIONS
AVAILABLE



DESIGN HAS SUCCESSFULLY PASSED MODIFIED ASTM G175 PHASE 2 PROMOTED
IGNITION TEST WITH 5000 PSIG OXYGEN

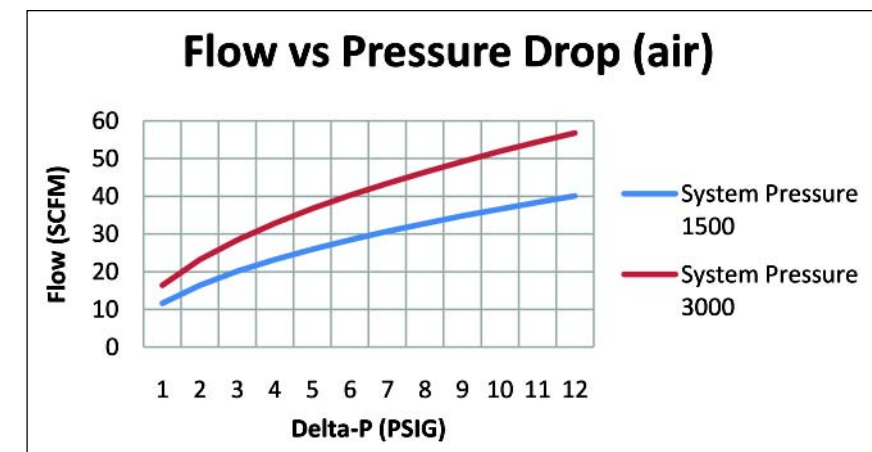

Chase Filters and Components • 1003 48th Street • Newport News VA 23607



25 SERIES BRASS INLINE FILTER

RATED OPERATING
PRESSURE: 5000 PSIG
OXYGEN



FLOW CAPABILITY:
Cv-0.7

COMPACT SIZE:
2.2" x 1.3"

MANY PORTING OPTIONS
AVAILABLE

SAFE, RELIABLE,
SIDE-SEAL DESIGN

**NEW: FLUTED SINTERED
10 MICRON REPLACEABLE ELEMENT**

- INCREASED SURFACE AREA
- INCREASED DIRT HOLDING CAPACITY
- INCREASED FLOW

PATENT PENDING

DESIGN HAS SUCCESSFULLY PASSED MODIFIED ASTM G175 PHASE 2 PROMOTED
IGNITION TEST WITH 5000 PSIG OXYGEN

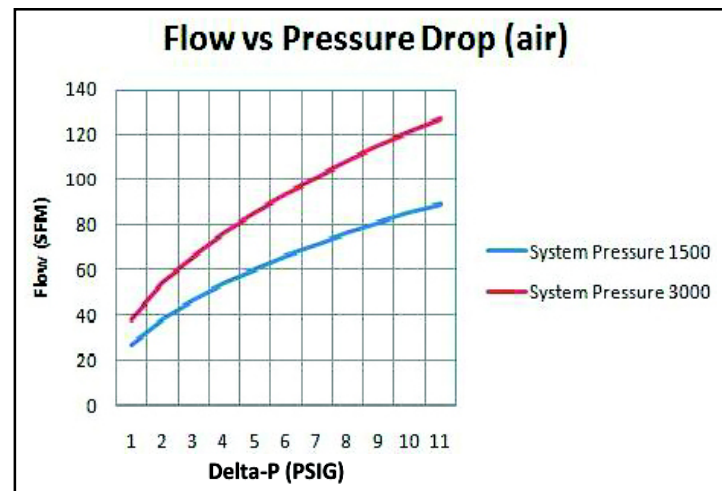

30 SERIES BRASS INLINE FILTER

RATED OPERATING
PRESSURE: 6000 PSIG
OXYGEN



MANY PORTING OPTIONS
AVAILABLE

FLOW CAPABILITY:
Cv-1.0

SAFE, RELIABLE,
SIDE-SEAL DESIGN

**NEW: FLUTED SINTERED
10 MICRON REPLACEABLE ELEMENT**



- INCREASED SURFACE AREA
- INCREASED DIRT HOLDING CAPACITY
- INCREASED FLOW

PATENT PENDING

DESIGN HAS SUCCESSFULLY PASSED MODIFIED ASTM G175 PHASE 2 PROMOTED
IGNITION TEST WITH 5000 PSIG OXYGEN

